

Stanzgestell und Stanzwerkzeuge Punching rack and punching tools

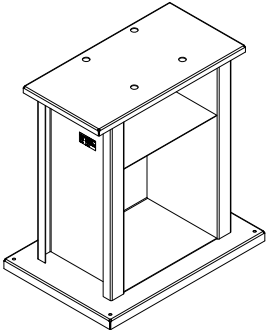

Z 981035

Stanzgestell,
für die 6fach Stanze Z 981034
Höhe 614 mm

Z 981035

Punching rack,
for the sixfold punching tool Z 981034
height 614 mm

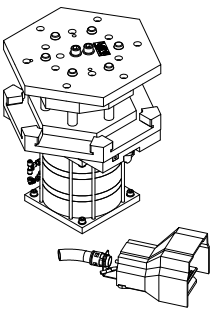

Z 981034

Stanze,
mit 6fach Aufnahme, Auslösung des
Stanzvorgangs mit Fußventil

Z 981034

Punching tool
with sixfold intake, punching
process triggered by foot valve

003002500

Siehe Verarbeitungshinweis!
Refer to processing information!

Stanzwerkzeuge für das Stanzgestell Z 981034 Punching tools for punching rack Z 981034

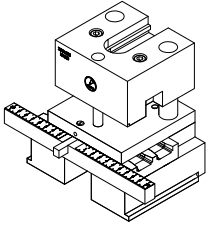

Z 981023

Stanzwerkzeug zur Schubstangenablängung und -lochung in einem Arbeitsgang

Z 981023

punching tool for punching operating rod drill holes and cutting operating rods to length in one work process

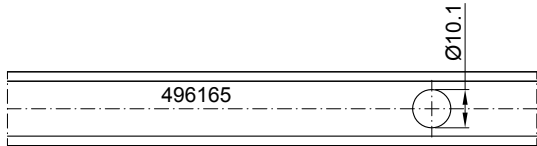

Schubstangenlochung

Operating rod punching of holes

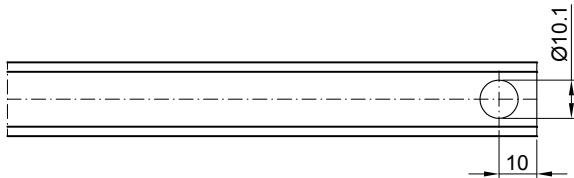

Schubstangenablängung und -lochung

Cutting the operating rod to length and punching of holes

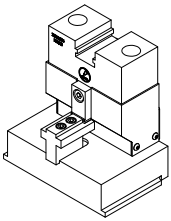

Z 981024

Stanzwerkzeug, mit pneumatischem Antrieb, zur Öffnung des Schubstangenkanals

Z 981024

Punching tool, with pneumatic drive for punching, to open the operating rod channel

Passend für Profil:
Suitable for profile:

B 840200

B 840201

B 840203

B 841200

B 841201

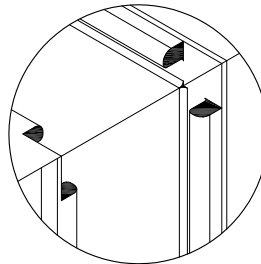
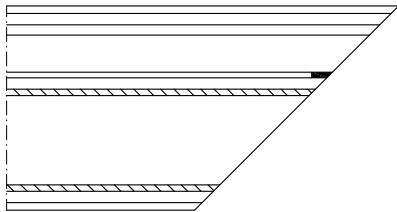
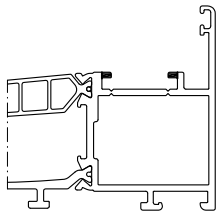

Stanzwerkzeuge für das Stanzgestell Z 981034 Punching tools for punching rack Z 981034

Passend für Profil:
Suitable for profile:

B 840200
B 840201
B 840203
B 840205
B 840206
B 840208
B 841200
B 841201

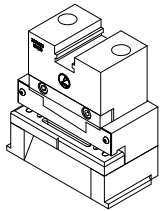

Z 981025

Stanzwerkzeug,
Griffausnehmung für Drehschwenkebel
Z 981008 und Z 981015

Z 981025

Punching tool,
handle notch for handle
Z 981008 and Z 981015

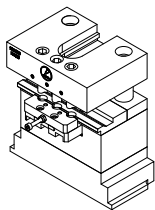
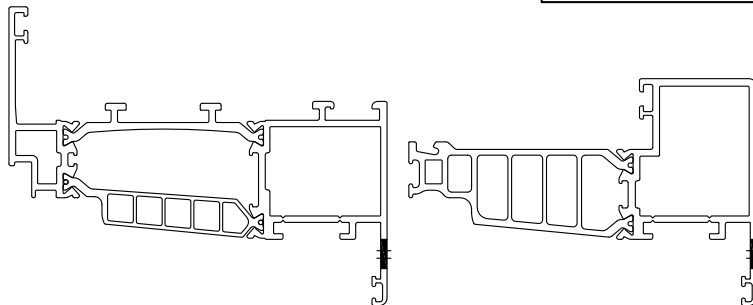
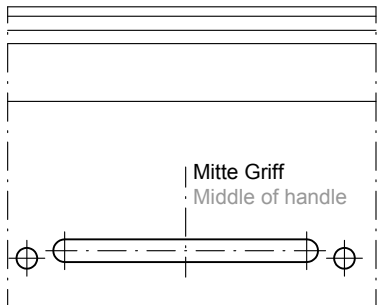

Z 981026

Stanzwerkzeug,
in Verbindung mit Stanzwerkzeug Z 981028,
Grifflochung für Einlassgetriebe Z 981010
und Z 981017
Griff Z 981011 und Z 981018

Z 981026

Punching tool,
in combination with punching tool
Z 981028, handle notch for rebate
gear Z 981010 and Z 981017
handle Z 981011 and Z 981018

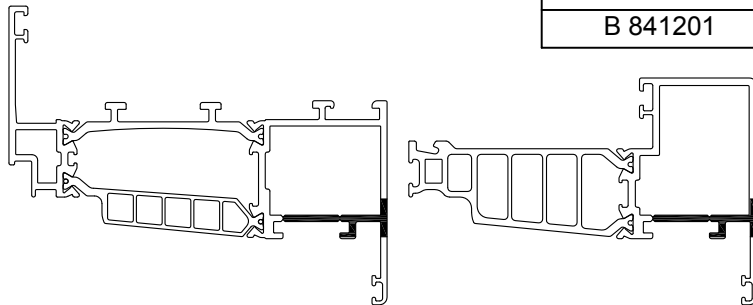
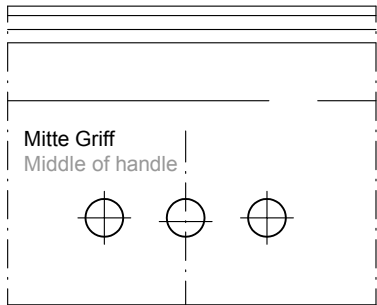

Passend für Profil:
Suitable for profile:

B 840200
B 840201
B 840203
B 841200
B 841201

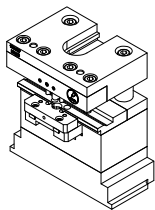

Z 981027

Stanzwerkzeug,
in Verbindung mit Stanzwerkzeug Z 981028,
Grifflochung für Einlassgetriebe Z 981010 und
Z 981017
Griff Z 981012 und Z 981019

Z 981027

Punching tool,
in combination with punching tool Z 981028,
handle notch for rebate gear
Z 981010 and Z 981017
handle Z 981012 and Z 981019

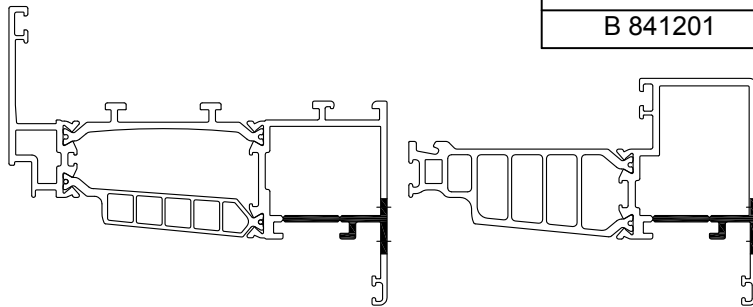
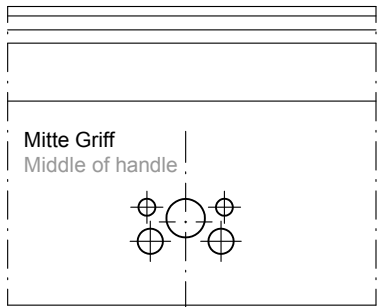

Passend für Profil:
Suitable for profile:

B 840200
B 840201
B 840203
B 841200
B 841201

005000400

Stanzbild
M 1:2
Punching scheme
Scale 1:2

Siehe Verarbeitungshinweis!
Refer to processing information!

Stanzwerkzeuge für das Stanzgestell Z 981034 Punching tools for punching rack Z 981034

Z 981028

Stanzwerkzeug,
Freimachung für Einlassgetriebe

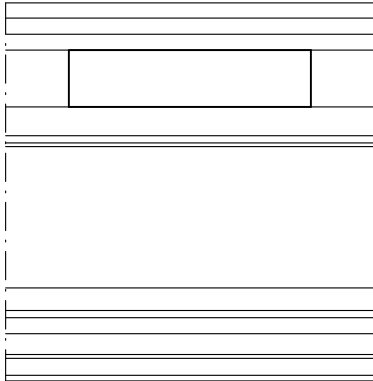

Z 981028

Punching tool,
baring for rebate gear

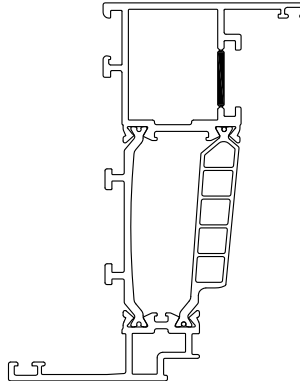

Passend für Profil:
Suitable for profile:

B 840200
B 840201
B 840203
B 841200
B 841201

Z 981029

Stanzwerkzeug,
Eckverbinderlochungen,
Flügelprofile

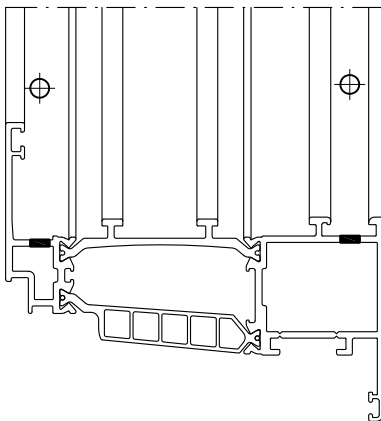

Z 981029

Punching tool,
punch holes for corner brackets,
sash profiles

Passend für Profil:
Suitable for profile:

B 840201
B 840203
B 840206
B 840208

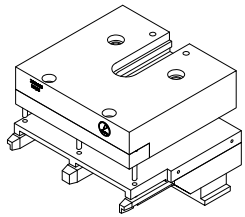
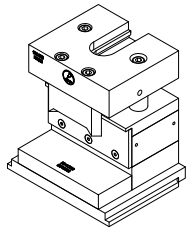

Stanzbild
M 1:2
Punching scheme
Scale 1:2

Siehe Verarbeitungshinweis!
Refer to processing information!

Stanzwerkzeuge für das Stanzgestell Z 981034 Punching tools for punching rack Z 981034

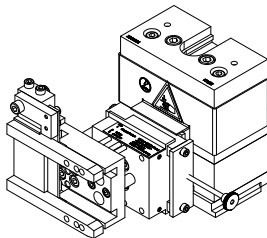

Z 981031

Stanzwerkzeug,
für Eckverbinder und
Stoßverbinder. Bearbeitung für
Blendrahmen und Sprosse

* Lochung für Kleberinjektion optional
zuschaltbar
Bohrungen Ø 5 mm

Z 981031

Punching tool,
for corner connections and
T-brackets. Processing for
fixed frame and transom

* Perforation for glue injection optional
switchable
Drill Ø 5 mm

Passend für Profil: Suitable for profile:		
B 840000	B 840305	B 841020
B 840001	B 840306	B 841080
B 840002	B 840308	B 841100
B 840003	B 840310	B 841300
B 840004	B 840311	B 841301
B 840005	B 840319	B 842000
B 840006	B 840325	B 842200
B 840007	B 840326	B 842201
B 840008	B 840327	B 842202
B 840009	B 840329	B 842203
B 840080	B 840330	B 842500
B 840300	B 840331	B 842501
B 840301	B 840332	B 842502
B 840302	B 840334	B 842613
B 840304	B 841000	B 842614

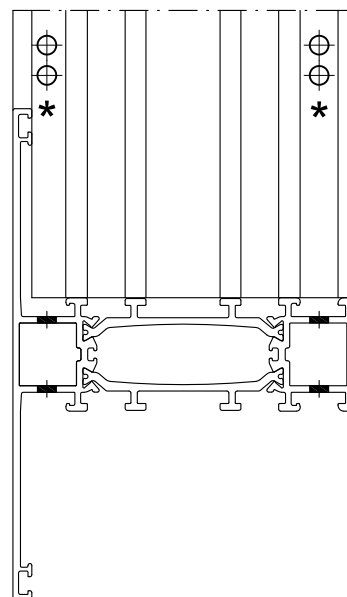
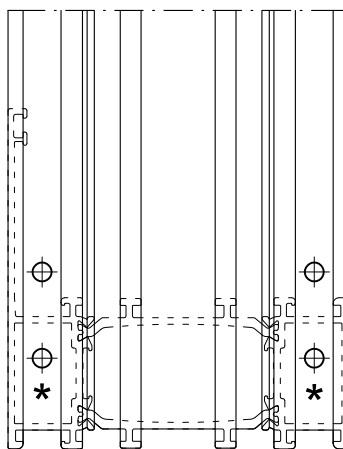
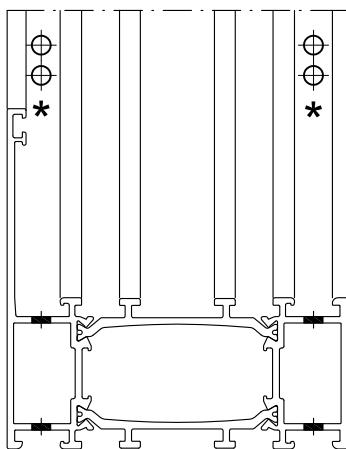
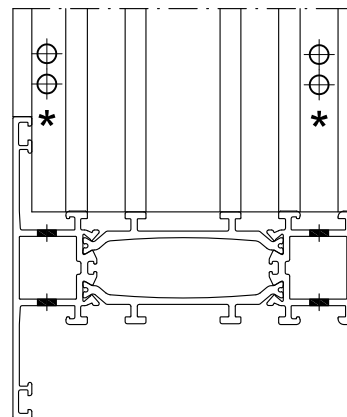
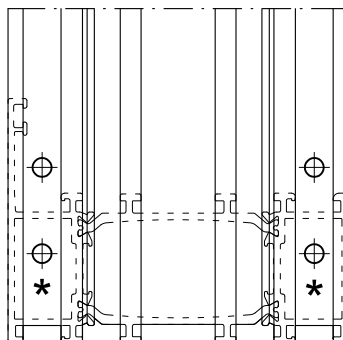
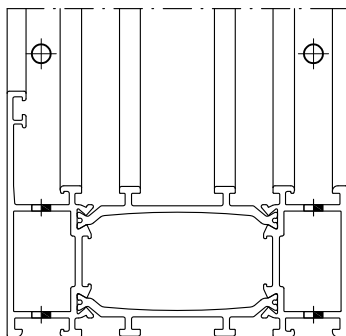

* Lochung wahlweise,
für nachträgliche Verklebung
* Hole optional,
for retro gluing after assembly

Stanzbild
M 1:2
Punching scheme
Scale 1:2

Siehe Verarbeitungshinweis!

Refer to processing information!

007002600

Stanzwerkzeuge für das Stanzgestell Z 981034 Punching tools for punching rack Z 981034

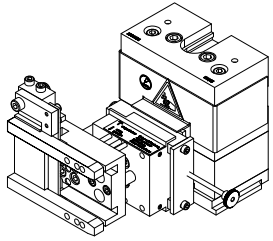

Z 921327

Stanzwerkzeug,
für Eckverbinder
Bearbeitung für Einspanndrahmen IF
Bohrung Ø 5 mm

Z 921327

Punching tool,
for corner connections
Processing for interlocking frames IF
Drill Ø 5 mm

Passend für Profil:
Suitable for profile:

B 841026
B 841027
B 841028
B 841029
B 841030
B 841031

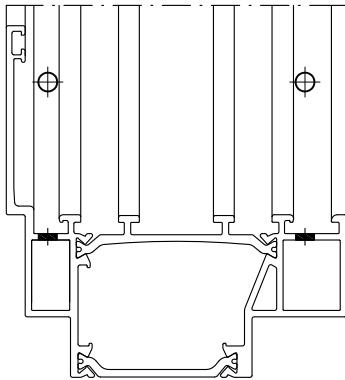

Stanzbild
M 1:2
Punching scheme
Scale 1:2

Siehe Verarbeitungshinweis!
Refer to processing information!

Stanzwerkzeuge für das Stanzgestell Z 981034 Punching tools for punching rack Z 981034

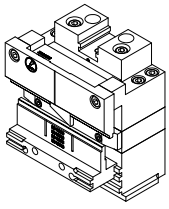

Z 981030

Stanzwerkzeug,
Falzbelüftung im Flügel

Z 981030

Punching tool,
rebate ventilation in the sash

Passend für Profil:
Suitable for profile:

B 840201

B 840203

B 840206

B 840208

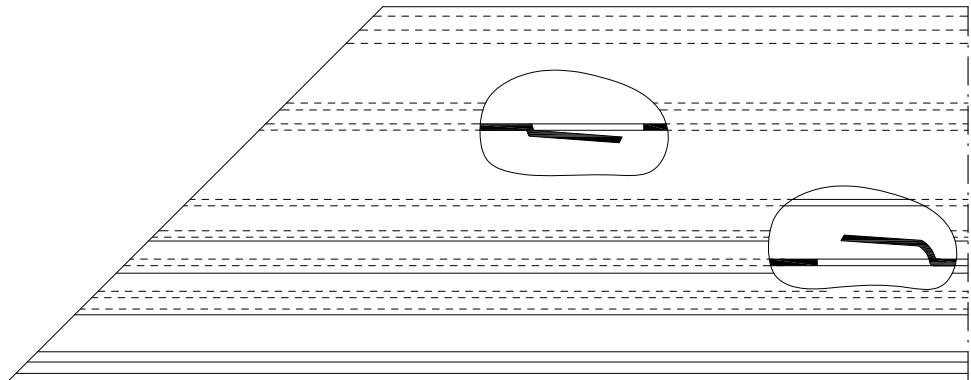
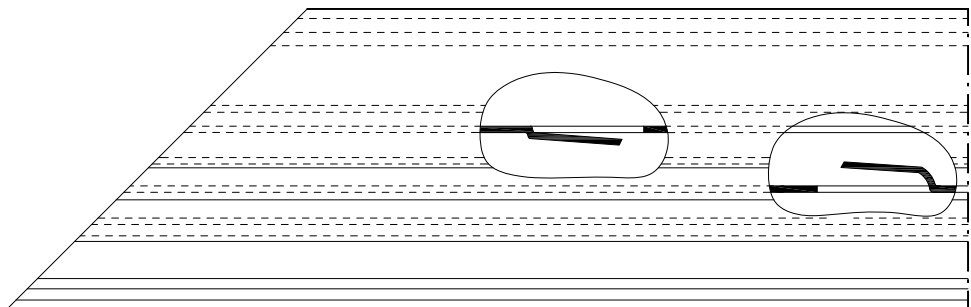
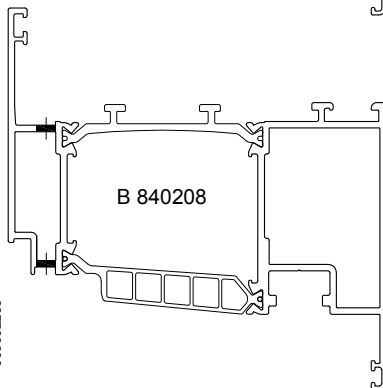
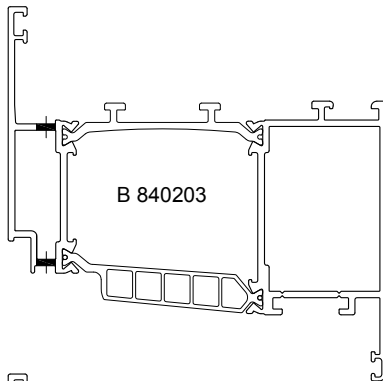
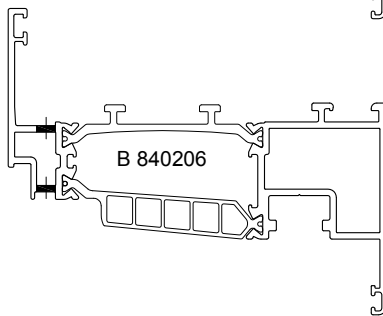
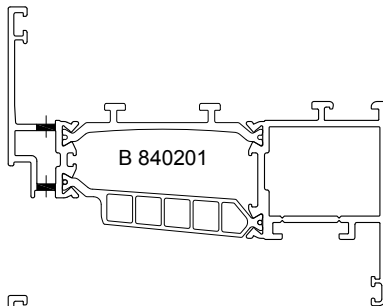

006002200

Siehe Verarbeitungshinweis!
Refer to processing information!

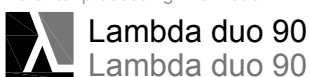

09/2014

Werkzeuge
Tools

Stanzwerkzeuge für das Stanzgestell Z 981034 Punching tools for punching rack Z 981034

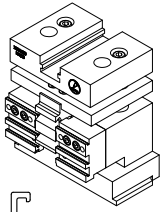

Z 981033

Stanzwerkzeug,
Freimachung für die Wasserablaufschlitze,
nicht für Lambda duo 90 IF Fensterflügel

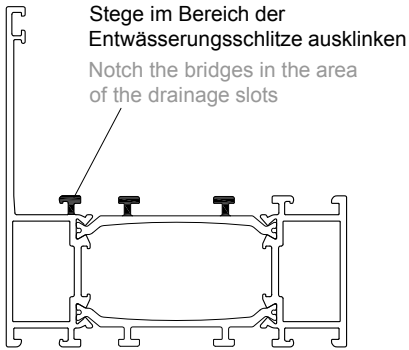
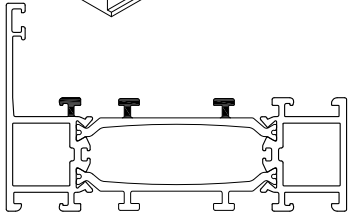

Z 981033

Punching tool,
for punching the exposing for the drainage slots,
not for Lambda duo 90 IF window sashes

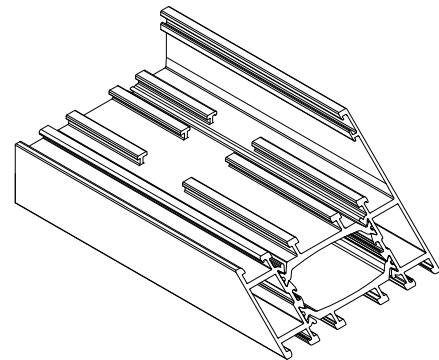
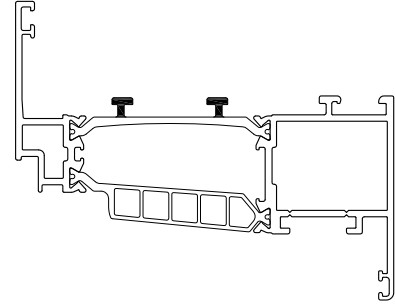
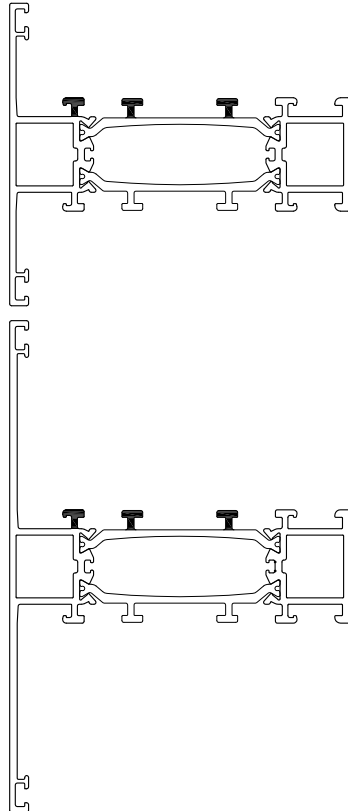

Passend für Profil:
Suitable for profile:

B 840000	B 840080	B 840322	B 841030
B 840001	B 840200	B 840325	B 841031
B 840002	B 840201	B 840326	B 841080
B 840003	B 840203	B 840327	B 841100
B 840004	B 840205	B 840329	B 841300
B 840005	B 840206	B 840330	B 841301
B 840006	B 840208	B 840331	B 842000
B 840007	B 840300	B 840332	B 842200
B 840008	B 840301	B 840333	B 842201
B 840009	B 840302	B 840334	B 842202
B 840020	B 840304	B 840335	B 842203
B 840021	B 840305	B 841000	B 842500
B 840022	B 840306	B 841020	B 842501
B 840027	B 840308	B 841026	B 842502
B 840031	B 840310	B 841027	B 842613
B 840032	B 840311	B 841028	B 842614
B 840033	B 840319	B 841029	

Siehe Verarbeitungshinweis!
Refer to processing information!

Stanzbild
M 1:2
Punching scheme
Scale 1:2



Stanzwerkzeuge für das Stanzgestell Z 981034 Punching tools for punching rack Z 981034

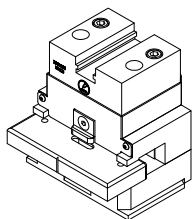

Z 981032

Stanzwerkzeug zum Ausstanzen der Wasserablaufschlitze in Blendrahmen und Sprosse

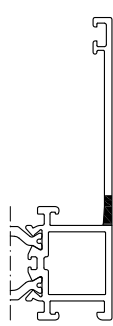
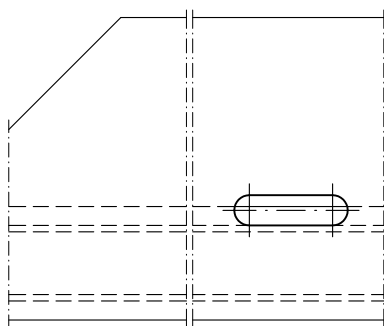
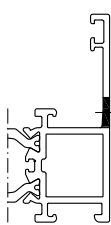
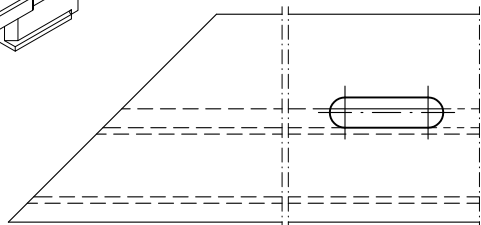

Z 981032

Punching tool for punching the drainage slots in the fixed frame and transom profile

Lambda duo 90

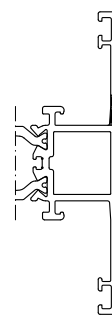
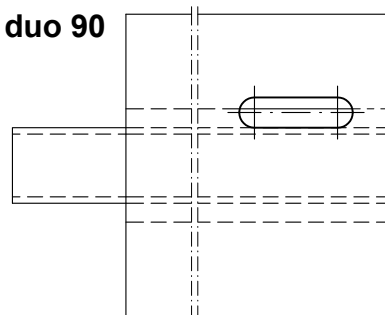

Lambda duo 90 IF

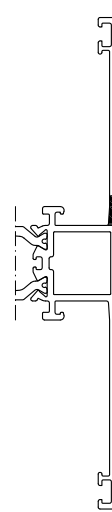
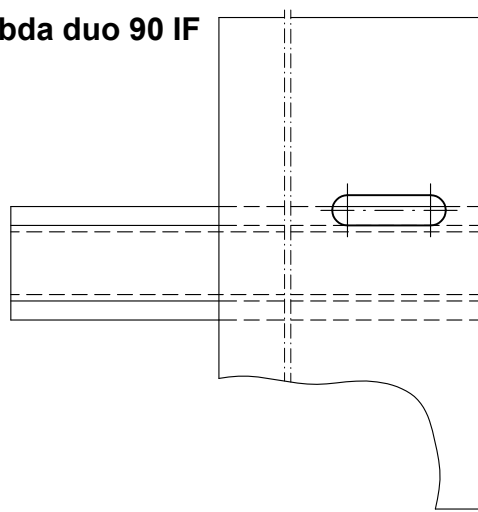

Passend für Profil: Suitable for profile:		
B 840000	B 840022	B 840308
B 840001	B 840027	B 840310
B 840002	B 840031	B 840311
B 840003	B 840032	B 840329
B 840004	B 840033	B 840330
B 840005	B 840080	B 840331
B 840006	B 840300	B 841000
B 840007	B 840301	B 841020
B 840008	B 840302	B 841080
B 840009	B 840304	B 841100
B 840020	B 840305	B 841300
B 840021	B 840306	B 841301

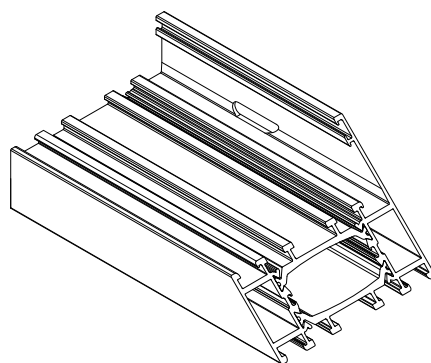

011002300

Siehe Verarbeitungshinweis!
Refer to processing information!

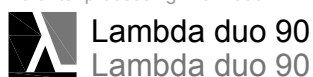

09/2014

Werkzeuge
Tools

11

Stanzbild
M 1:2
Punching scheme
Scale 1:2